

Taikan

HIGH-END INTELLIGENT EQUIPMENT TURNKEY SOLUTION SERVICE PROVIDER



HIGH-PRECISION CNC HORIZONTAL TURNING(MILLING) COMPOUND

High-end intelligent equipment turnkey solution service provider

Taikan



NO. **183**

Shenzhen's Top 500
Enterprises in 2023

NO. **175**

Guangdong top 500
manufacturers

TOP **100**

Top 100 domestic enterprises

Bao an District, Shenzhen
Top 100 enterprises by tax contribution
Top 100 enterprises by innovation
Top 100 enterprises by output value
Top 100 enterprises by added value

COMPANY PROFILE

Guangdong Create Century Intelligent Equipment Group Co., Ltd. (Create Century, Stock code: 300083) was listed on the Shenzhen Stock Exchange in 2010 and transformed into Intelligent Equipment Co., Ltd. in 2016. The company is a national high-tech enterprise of intelligent equipment, integrating R&D, production, sales and service. With nearly 20 years of industry experience, it can provide customers with high-quality equipment and intelligent solution service. It is one of the companies with the most complete technology and the widest product range among similar domestic companies.



4 R&D Centers

Shenzhen Suzhou
Shanghai Xi'an



500+ R&D Engineers

The company boasts a technical advisory board consisting of industry-leading technical experts from Mainland China, Taiwan, South Korea, Malaysia, Germany, and other regions, along with a dedicated R&D team of over 500 professionals.



700+ Core Patents

Invention patents-----168
Utility model patents-----509
Design patents-----121
Software copyrights-----88

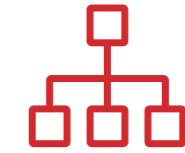

4 Strategic Cooperation Institutions

Shenzhen academician <expert> workstation
Intelligent precision machining key technology engineering laboratory
Guangdong engineering technology research center
Shenzhen enterprise technology center

Four Production Bases



● Huzhou Manufacturing Headquarters



● Yibin Manufacturing Base



● Dongguan Manufacturing Base



● Suzhou Manufacturing Base

机械主轴 MECHANICAL SPINDLE

- 前侧采用进口P4级高刚性的双列圆柱滚子轴承和高刚性的角接触球轴承；
- 后侧采用进口P4级高刚性的双列圆柱滚子轴承，通过合理的优化布局，保证了主轴的高精度、高效率、高刚性。
- The front side is equipped with imported P4 grade high-rigidity double-row cylindrical roller bearings and high-rigidity angular contact ball bearings.
- The rear side is equipped with imported P4 grade high-rigidity double-row cylindrical roller bearings. Through a well-optimized layout, it ensures high precision, high efficiency, and high rigidity of the spindle.

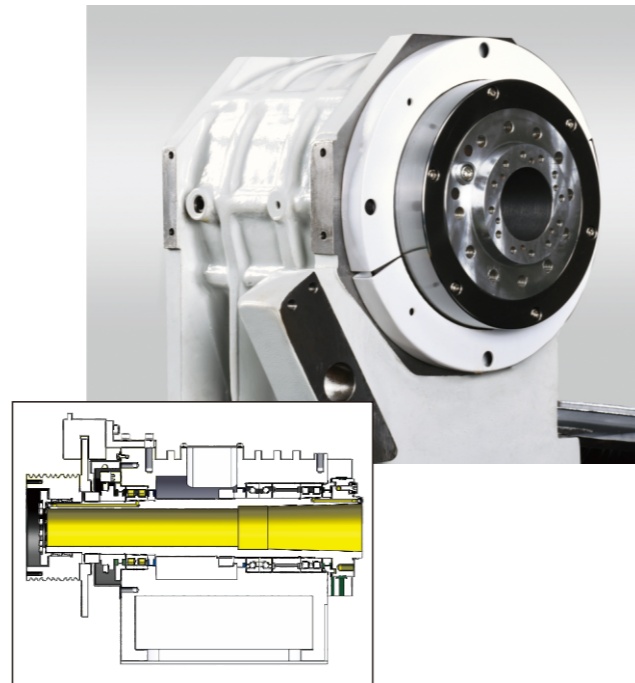

主轴优点 Spindle advantages

- 主轴结构紧凑，轴承布局合理，严格的装配及检测条件，保证了主轴的高精度及稳定性；
- 主轴电机采用高转速大扭矩电机，可以满足高效率加工的需要；
- 通过对主轴的优化设计，减小了主轴单元的发热量，通过对主轴温度和热延伸量的测控，保证主轴单元的加工稳定性；
- 配备高精度磁栅编码器，降低测量误差。
- The spindle features a compact structure and a well-designed bearing layout, along with strict assembly and testing conditions, ensuring high precision and stability.
- The spindle motor adopts a high-speed and high-torque motor, meeting the requirements for efficient machining.
- Through optimized design, the heat generation of the spindle unit is reduced, and temperature and thermal expansion are measured and controlled to ensure machining stability.
- Equipped with a high-precision magnetic encoder, it reduces measurement errors.

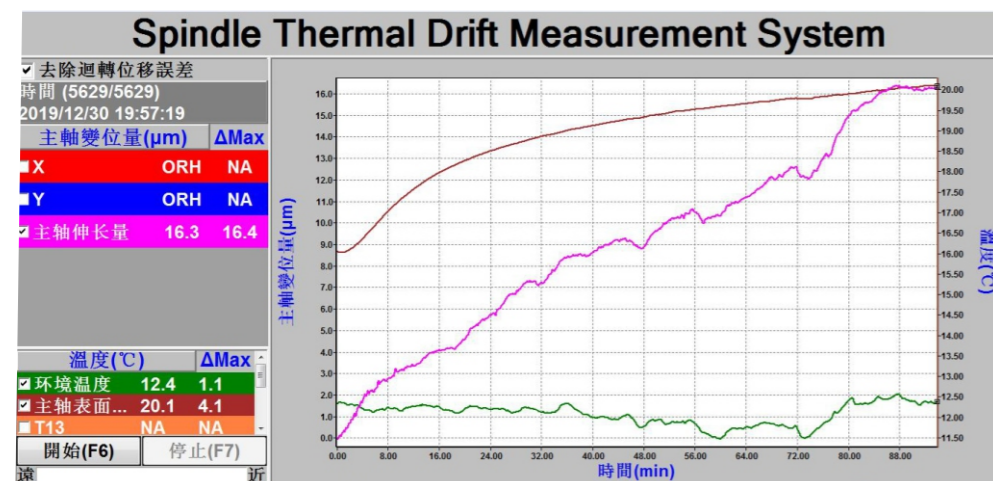

配FANUC系统 FANUC SYSTEM

A2-5机械主轴功率扭矩图
A2-5Power-Torque Chart of the Mechanical Spindle

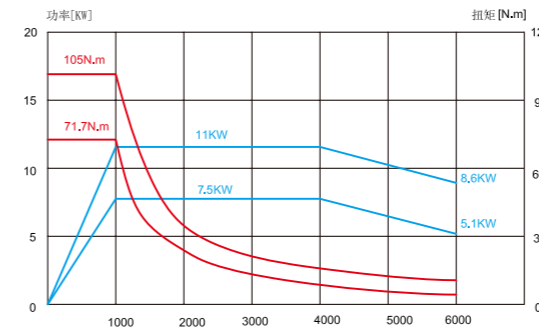

A2-6机械主轴功率扭矩图
A2-6Power-Torque Chart of the Mechanical Spindle

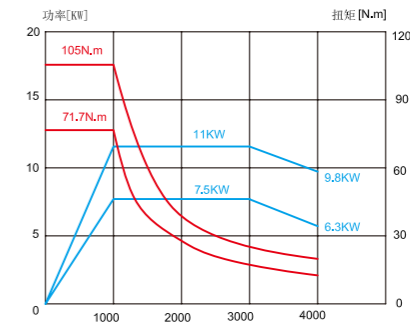

A2-8机械主轴功率扭矩图
A2-8Power-Torque Chart of the Mechanical Spindle

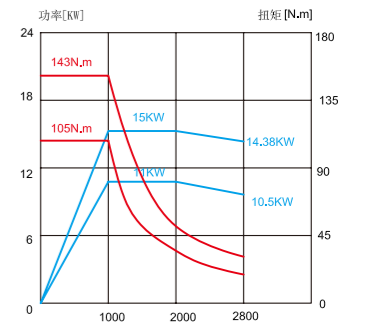

配西门子系统 SIEMENS SYSTEM

A2-5机械主轴功率扭矩图
A2-5Power-Torque Chart of the Mechanical Spindle

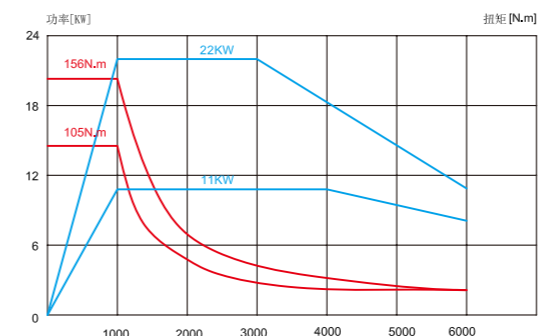

A2-6机械主轴功率扭矩图
A2-6Power-Torque Chart of the Mechanical Spindle

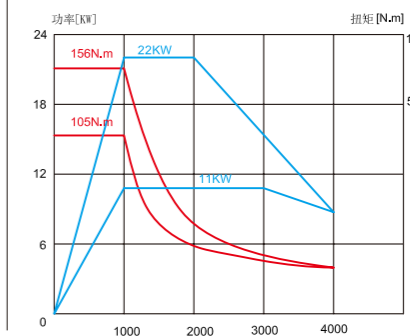

A2-8机械主轴功率扭矩图
A2-8Power-Torque Chart of the Mechanical Spindle

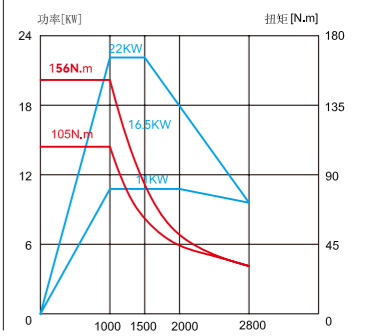

电主轴 ELECTRIC SPINDLE

- ★采用进口P4级双列圆锥滚子及滚珠轴承，精度高，寿命长。
- ★高刚性电主轴可以大幅提高生产效率。
- ★电机直联带动主轴转动，减小了传动误差，低振动，具有高转速特性，能够大幅提高表面光洁度，减少刀具损失。
- ★优化了主轴结构，主轴故障率低，通过水冷结构减小了主轴的发热量，保证主轴的加工稳定性。
- ★Adopting imported P4 grade double-row tapered roller and ball bearings, the machine features high precision and long service life.
- ★The high rigidity electric spindle greatly improves production efficiency.
- ★The direct drive of the motor to the main spindle reduces transmission errors, minimizes vibration, and exhibits high-speed characteristics, leading to significantly improved surface smoothness and reduced tool wear.
- ★The main spindle structure has been optimized to ensure low failure rate and enhanced processing stability. The water cooling system reduces heat generation, further ensuring the stability of the main spindle during operation.

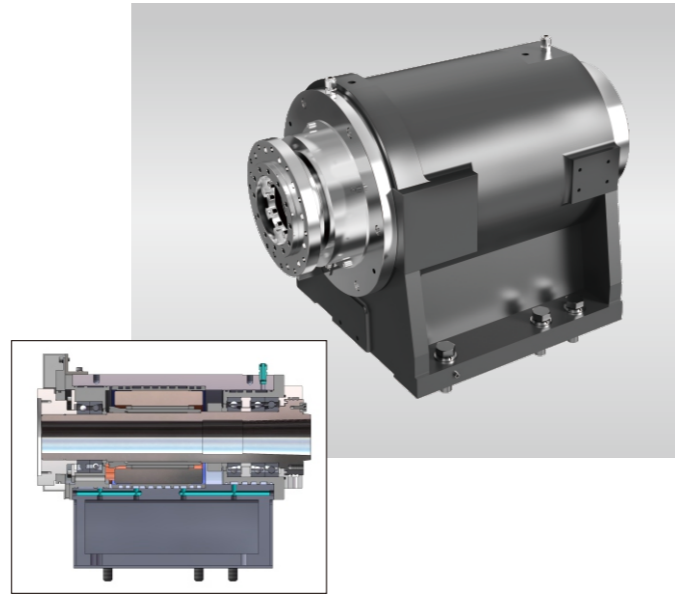

配FANUC系统 FANUC SYSTEM

A2-4电主轴功率扭矩图 A2-4 Electric Spindle Power-Torque Chart

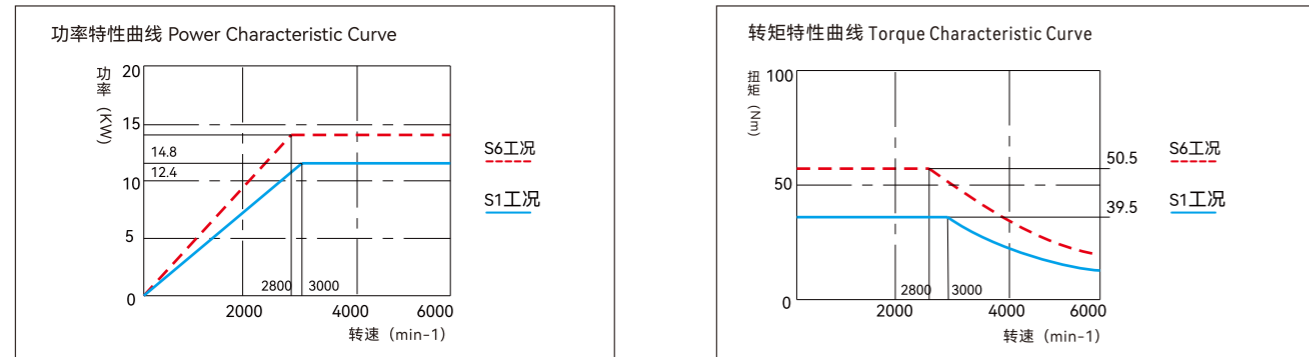

A2-5电主轴功率扭矩图 A2-5 Electric Spindle Power-Torque Chart

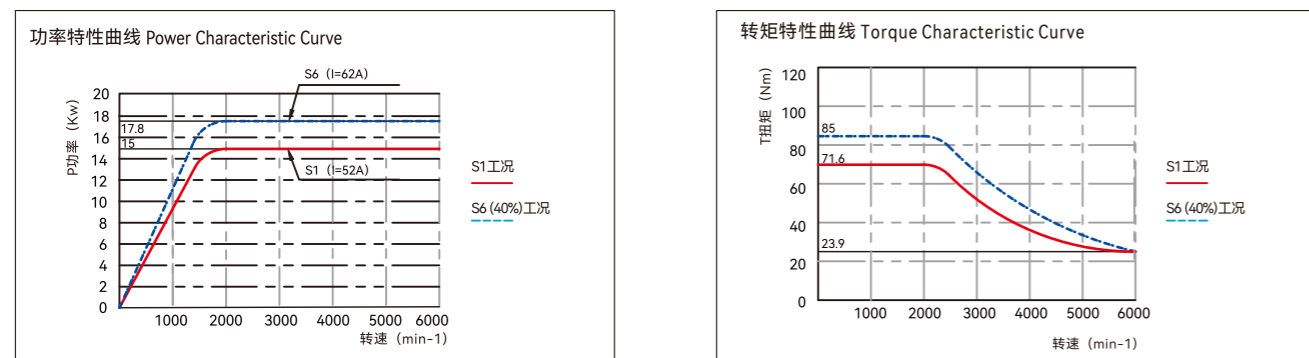

A2-6电主轴功率扭矩图 A2-6 Electric Spindle Power-Torque Chart

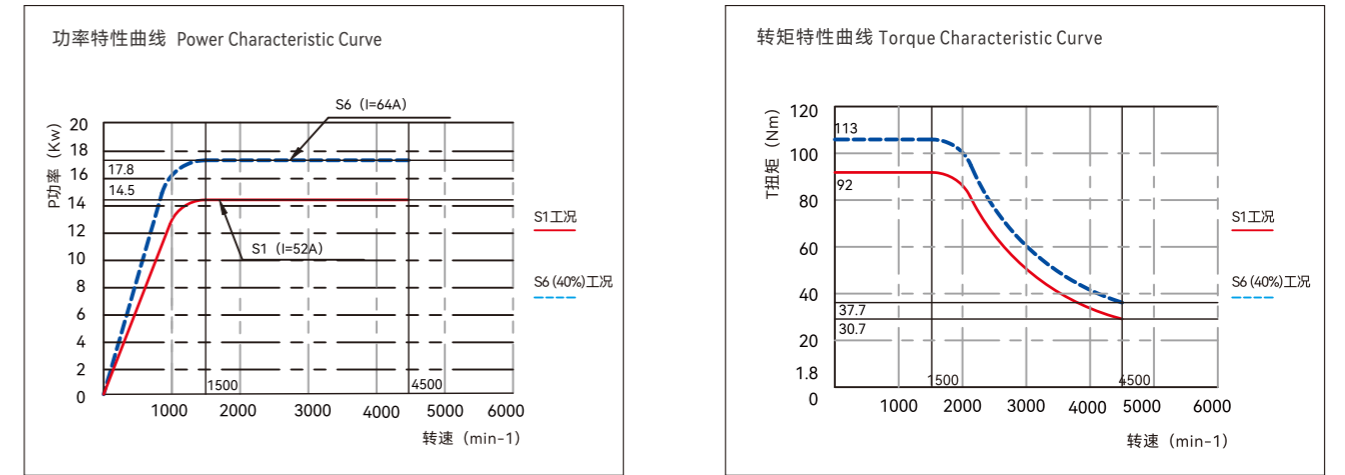

A2-8电主轴功率扭矩图 A2-8 Electric Spindle Power-Torque Chart

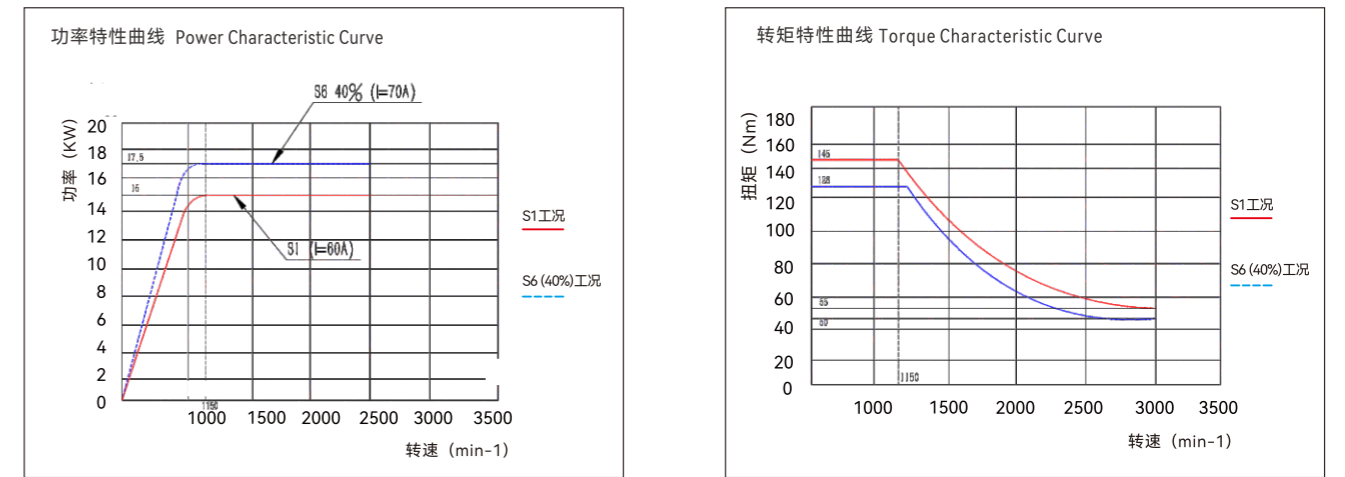

配西门子系统 SIEMENS SYSTEM

A2-4电主轴功率扭矩图 A2-4 Electric Spindle Power-Torque Chart

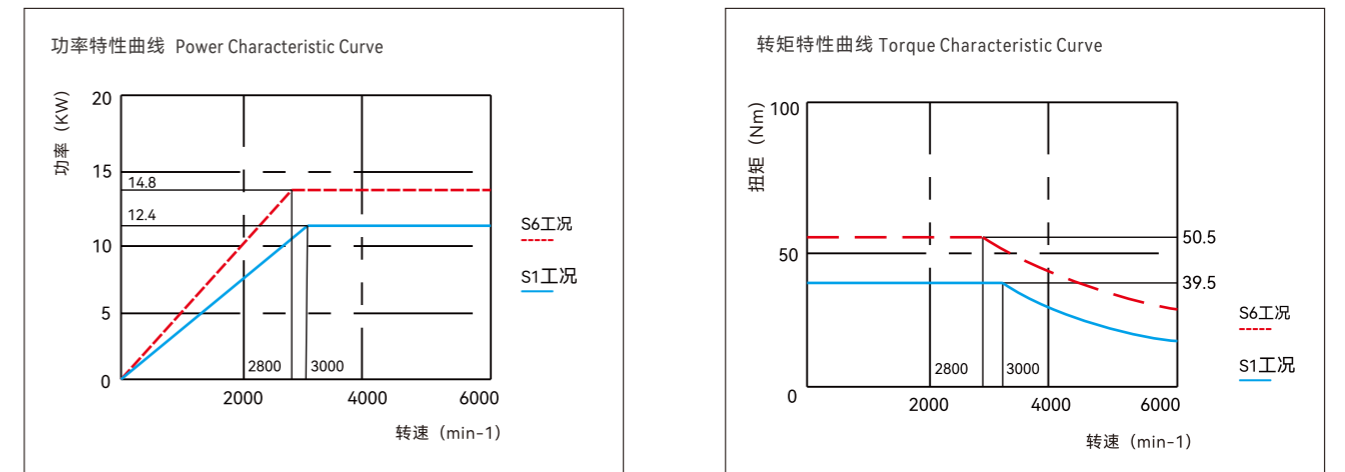

A2-5电主轴功率扭矩图 A2-5 Electric Spindle Power-Torque Chart

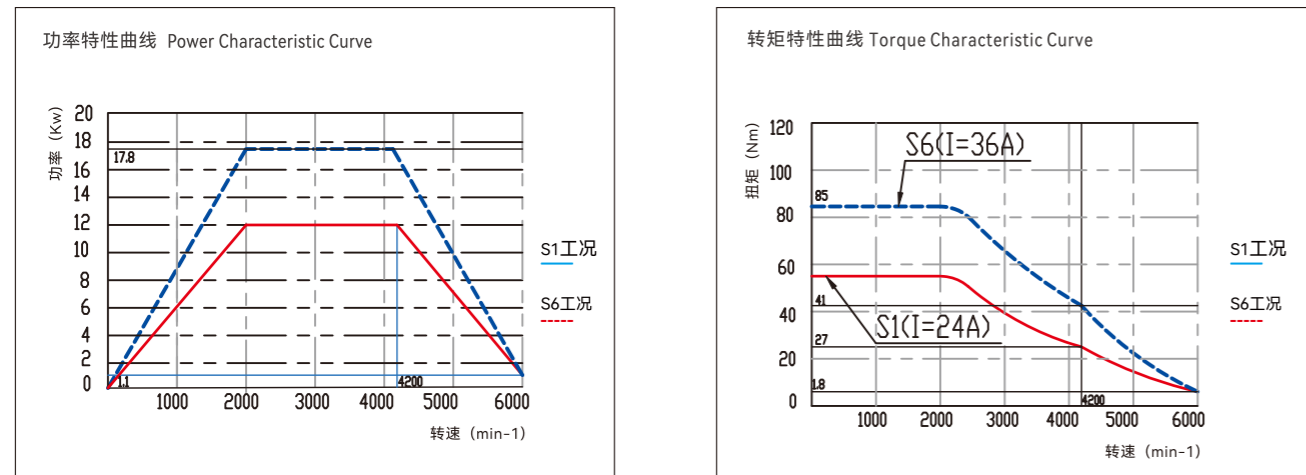

动力刀塔 SERVO TURRET

采用伺服分度、牙盘定位的结构，不仅具有良好的刚性，而且还具有很高的分度速度。刀塔分度动作可以和坐标运动同时进行，进一步提高了机床的工作效率。动力传动齿轮采用油气润滑，最高转速可达4000-6000rpm。高刚性的刀塔结构可得到很高的加工表面质量。

The structure using servo indexing and tooth positioning not only has good rigidity, but also has high indexing speed. The indexing action of the turret can be carried out simultaneously with coordinate motion, further improving the working efficiency of the machine tool. The power transmission gears are lubricated with oil and gas, with a maximum speed of 4000-6000rpm. A highly rigid turret structure can achieve high machining surface quality.

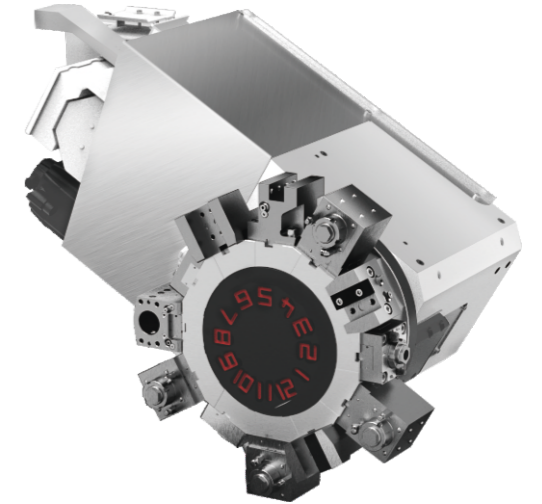

伺服刀架参数 Servo turret parameters

工位数	Tool capacity	12
Y轴中心高(mm)	Tool indexing time	160
Y轴行程(mm)	External tool dimensions	±50
刀盘对边尺寸(mm)	Maximum boring tool diameter	290
油压(MPa)	Positioning accuracy	5
重复定位精度	Repeatability	±1"

扭力大 / 噪音低

重复精度可达: ±2"

动力刀盘旋转分度采用专用型伺服马达驱动，动力轴采用伺服主轴马达驱动。

A2-6电主轴功率扭矩图 A2-6 Electric Spindle Power-Torque Chart

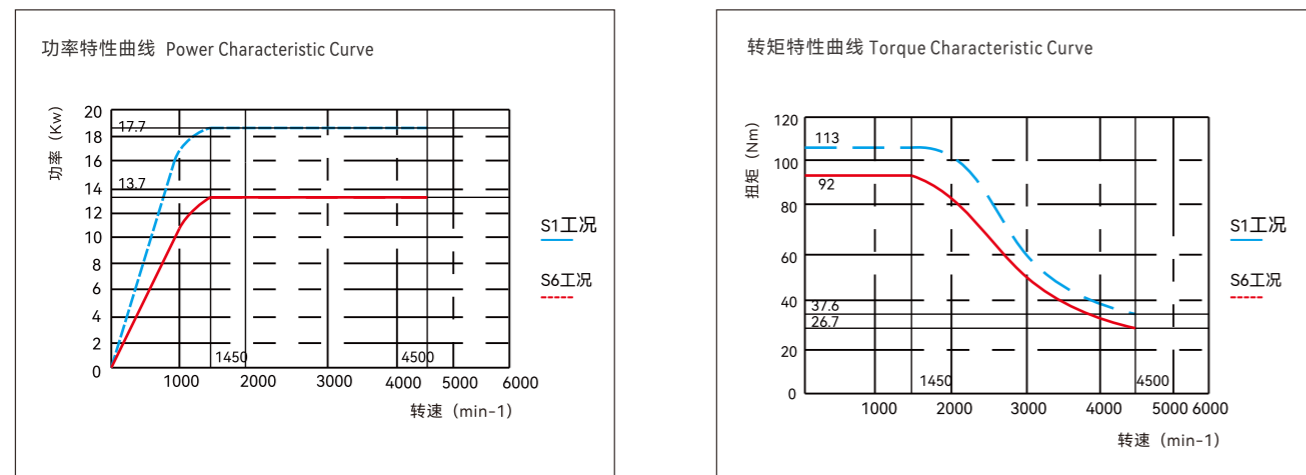

液压套筒式尾架 HYDRAULIC SLEEVE-TYPE TAILSTOCK

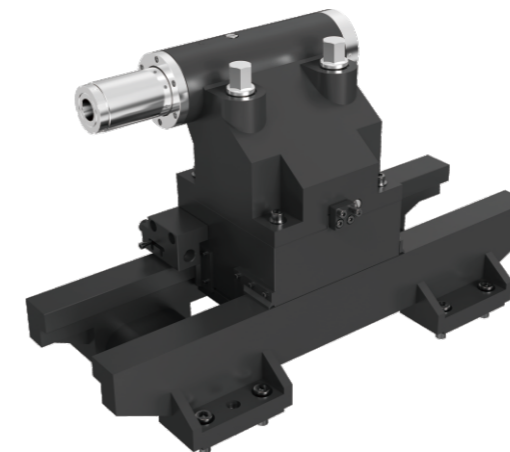

A2-8电主轴功率扭矩图 A2-8 Electric Spindle Power-Torque Chart

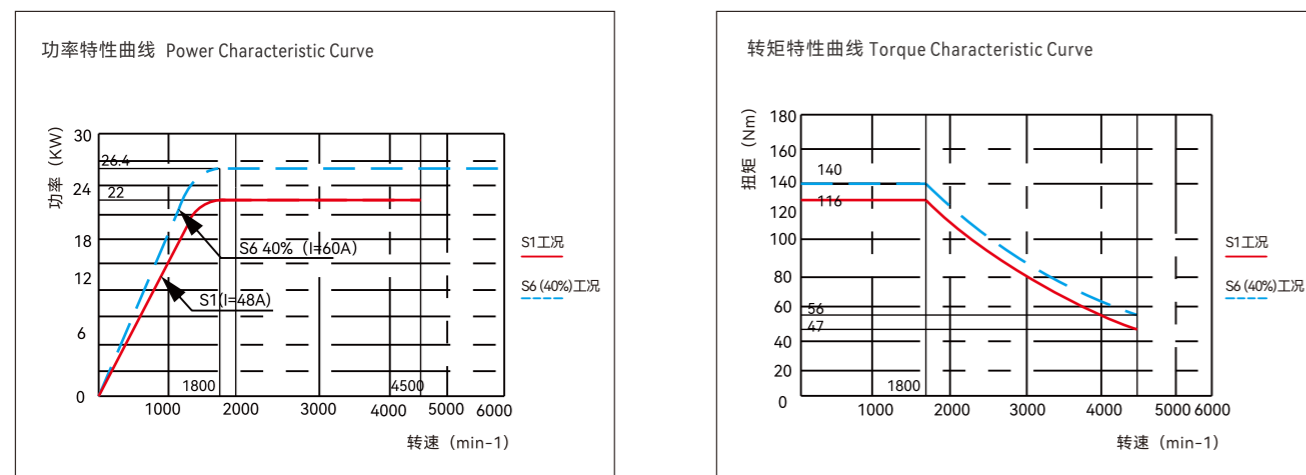

精密丝杠/导轨 PRECISION BALL SCREW/GUIDE RAIL

X/Z轴采用进口Φ32 (C3级) 大直径高速静音滚珠丝杠，合理的预拉伸量有效防止温升变形，提高定位精度；快速进给可达30m/min，高效率，定位精度±0.003mm；X/Z轴采用35mm进口滚柱重负荷型导轨，刚性好，抑制振动，提高刀具寿命，精度高，响应速度快，使用寿命长，可以满足客户长期的使用需求。

The X/Z axes are equipped with imported Φ32 (C3 grade) large-diameter high-speed and low-noise ball screws. The reasonable preloading effectively prevents thermal deformation and improves positioning accuracy. The rapid feed can reach 30m/min, ensuring high efficiency and a positioning accuracy of ±0.003mm. The X/Z axes adopt 35mm imported heavy-duty cylindrical roller guide rails, providing excellent rigidity, vibration suppression, extended tool life, high precision, fast response, and long service life. These features meet the long-term usage requirements of customers.

- ★ 大跨距硬轨结构设计，高刚、性强，承载能力强。
- ★ 燕尾式结构，下压板锁紧时更加可靠。
- ★ 套筒行程长，液压顶紧工件，顶紧力可调，满足不同种类产品的加工需求。
- ★ Large-span hardened rail structure design, high rigidity and strong load-bearing capacity.
- ★ Dovetail structure for more reliable locking when the pressure plate is tightened.
- ★ Long sleeve stroke, hydraulic clamping of workpieces with adjustable clamping force, meeting the processing needs of different types of products.

[智能制造 INTELLIGENT MANUFACTURING]

模组化设计 MODULAR DESIGN

- 加装桁架自动化、料仓、在线清洗、在线检测等功能后组成一条多功能车削生产线。
- 可以加远程监控功能和数据采集功能，与工厂的EPR、MES等智能化系统无缝对接。
- After adding functions such as truss automation, silo, online cleaning, and online testing, a multifunctional turning production line is formed.
- Remote monitoring and data collection functions can be added to seamlessly connect with the factory's EPR, MES and other intelligent systems.

机械手自动化模式
MANIPULATOR AUTOMATION MODE

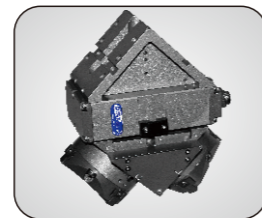

气动摆缸\
气动手爪集成，
90度对置。
Pneumatic swing cylinder\
Pneumatic gripper integrated,
90 degrees opposite.

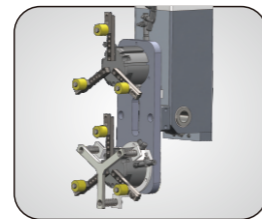

气动摆缸\
气动手爪集成，
水平对置。
Pneumatic swing cylinder\
Pneumatic gripper integrated,
horizontally opposite.

机器人自动化模式
ROBOT AUTOMATION MODE

搬运能力可达210KG
HANDLING CAPACITY UP TO 210KG

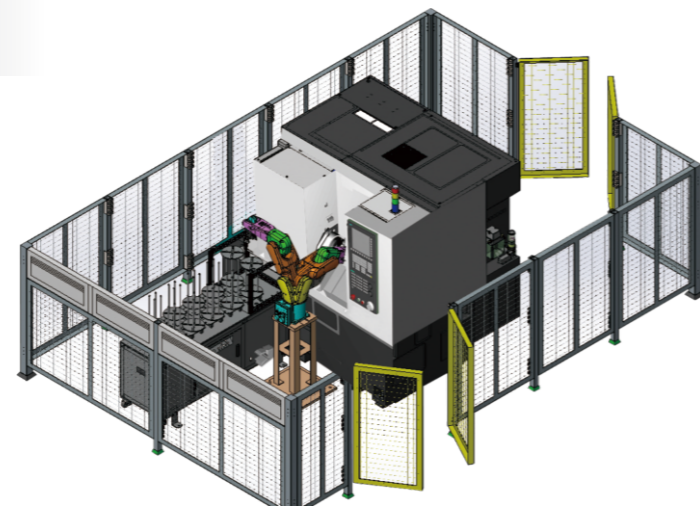

工件在线测量装置

Workpiece online measuring device

通过设定接触感测器，可以自动计算已经加工工件的精度，并进行刀具补偿保证连续加工稳定性。

By setting contact sensor, the accuracy of machined workpiece can be automatically calculated, and tool compensation can be performed to ensure continuous machining stability.

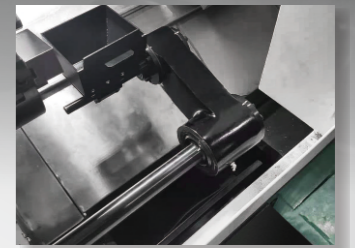

自动工件收集器

Automatic workpiece collector

在不打开前门的状态下，将加工结束后的工件自动传输到机床外部，提高加工效率。

Automatically transfers the processed workpieces outside the machine without opening front door, improving processing efficiency.

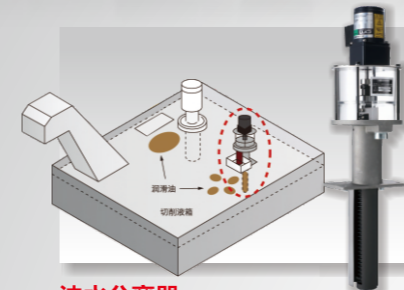

油水分离器

Oil-water separator

把切削液中废弃的油污分离出来，延长切削液使用寿命，节约成本，保护环境。

Separates waste oil from cutting fluid, prolongs cutting fluid life, saves costs, and protects the environment.



全自动对刀仪

Fully automatic tool setter

对于操作者来说，只需要在NC系统中操作菜单键或M代码就可以自动将刀具数据补偿到NC系统中。

For the operator, only menu key or M code in NC system is needed to automatically compensate tool data to the NC system.

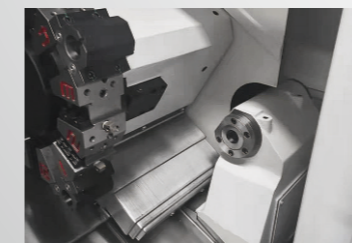

可编程尾座

Programmable tailstock

可适用不同长度的棒料，精度稳定、可操作性强、简单灵活、刚性优越。

It can be used for bars of different lengths, with stable accuracy, strong operability, simple and flexible, and excellent rigidity.

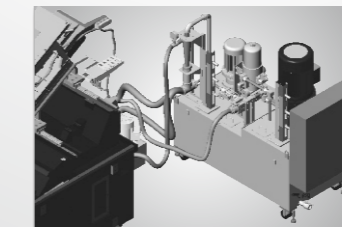

高压冷却装置

High-pressure cooling device

能提高加工效率、延长刀具使用寿命，和实现紫铜、不锈钢等材料高速断屑功能，可选不同规格的冷却泵。

It can improve processing efficiency, extend tool service life, and achieve high-speed chip breaking for materials such as copper and stainless steel. Cooling pumps of different specifications are optional.



油雾收集器

Oil mist collector

吸收并处理油雾状的冷却液和油类，保持良好的车间环境，保障员工身体的身体健康，延长电力系统的的使用寿命。

It absorbs and processes coolant and oil in the form of oil mist, maintains a good workshop environment, protects the health of employees, and extends the service life of power system.



棒料输送机

Bar conveyor

配置棒料输送功能，可以实现自动上料长时间无人运转

Equipped with bar conveying function to realize automatic loading and long-term unmanned operation.

高精度数控卧式车铣复合

HIGH-PRECISION CNC HORIZONTAL TURNING (MILLING) COMPOUND

工艺强大，一机多能、多品种、小批量，一次装夹可完成多样加工的个性化市场制造需求，满足复杂的零件加工需要，广泛应用于阀门、船舶和工程机械等领域，尤其受到汽车零部件制造企业的青睐。

Powerful technology enables the machine to be versatile, capable of handling multiple varieties and small batch production. With the ability to complete various machining processes in a single setup, it meets the demands of personalized market manufacturing. It is suitable for complex part machining and finds wide applications in industries such as valves, shipbuilding, and construction machinery. It is especially favored by automotive component manufacturers.



高精度数控卧式车铣复合

L-25Y/L-35Y/L-45Y/L-45YP

- ★ 高刚性、低振动的30度斜床鞍结构设计延长了刀具使用寿命。
- ★ 高精度、高刚性主轴结构，主轴跳动0.003mm以内。
- ★ 高精度、高刚性、高稳定性Y轴动力刀塔。
- ★ X、Z轴丝杆采用进口C3级双向预紧力丝杆，高速静音，30m/min，响应速度快，定位精度高。
- ★ 按人体工程学原理设计，摆动式操作面板。
- ★ 自动化多种选项，实现更高生产效率。

- ★ High precision, high rigidity, and low vibration 30-degree slant bed saddle design extends tool life.
- ★ High precision, high rigidity spindle structure with spindle runout within 0.003mm.
- ★ High precision, high rigidity, and high stability Y-axis power turret.
- ★ X and Z axes adopt imported C3-grade bi-directional preloaded ball screws, featuring high speed, low noise, fast response, and high positioning accuracy.
- ★ Designed according to ergonomic principles, with a swing-type operation panel.
- ★ Multiple automation options available to achieve higher production efficiency.
- ★ Incorporating advanced technologies, such as high precision, high efficiency, and intelligent features.

高精·高效·智能

HIGH PRECISION HIGH EFFICIENCY INTELLIGENT

30°一体式床身结构特性
Characteristics of the 30° integrated bed structure

完美的刚性与稳定性
Perfect rigidity and stability

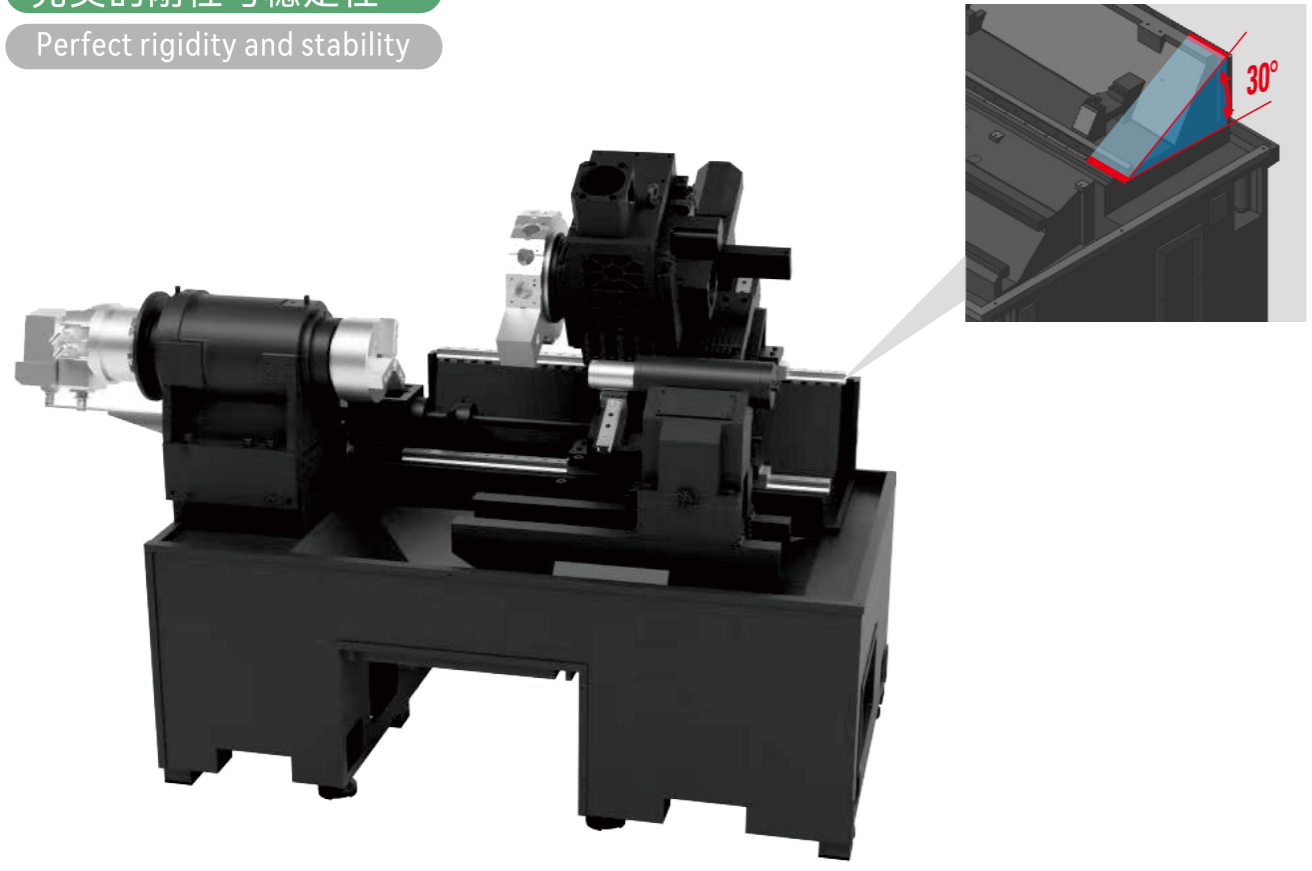

高刚性:
30°一体式高刚性斜床身设计, 经过有限元分析, 优化加强筋布局, 使机床具有优良的刚性、低振动, 同时实现最小占地面积。

高稳定性:
所有铸件均经过长时间的自然时效处理, 并在精加工前进行二次振动时效处理, 以消除铸件内部残余应力, 确保精度持久稳定。

高承载性
X/Z轴采用进口P级重载荷35mm滚柱导轨采用大跨距结构设计, 可满足高负荷作业。

High rigidity:
The 30° integrated high-rigidity slant bed design, optimized with finite element analysis and reinforced rib layout, provides excellent rigidity, low vibration, and minimal footprint for the machine tool.

High stability:
All castings undergo long-term natural aging treatment and secondary vibration aging treatment before precision machining to eliminate residual internal stress in the castings, ensuring long-lasting stability of accuracy.

High load-bearing capacity:
The X/Z axes are equipped with imported P-grade heavy-duty 35mm roller guide ways with a large span structure design, capable of handling high-load operations.

机器外观尺寸图 Machine exterior dimensions diagram

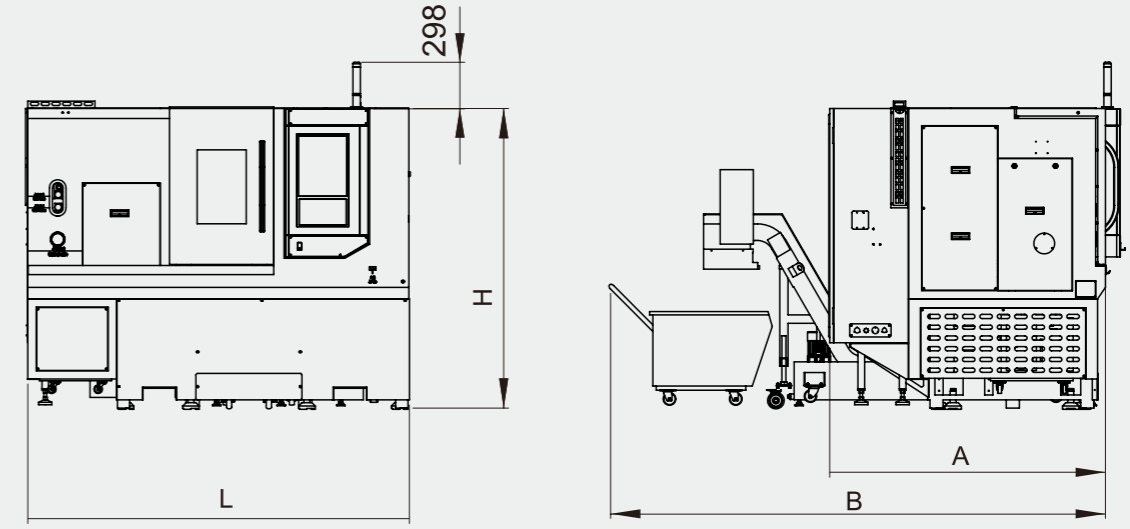

标准尺寸 Standard dimensions

设备型号 Equipment model	L	H	A	B
L-35Y	2400	1980	1920	2950

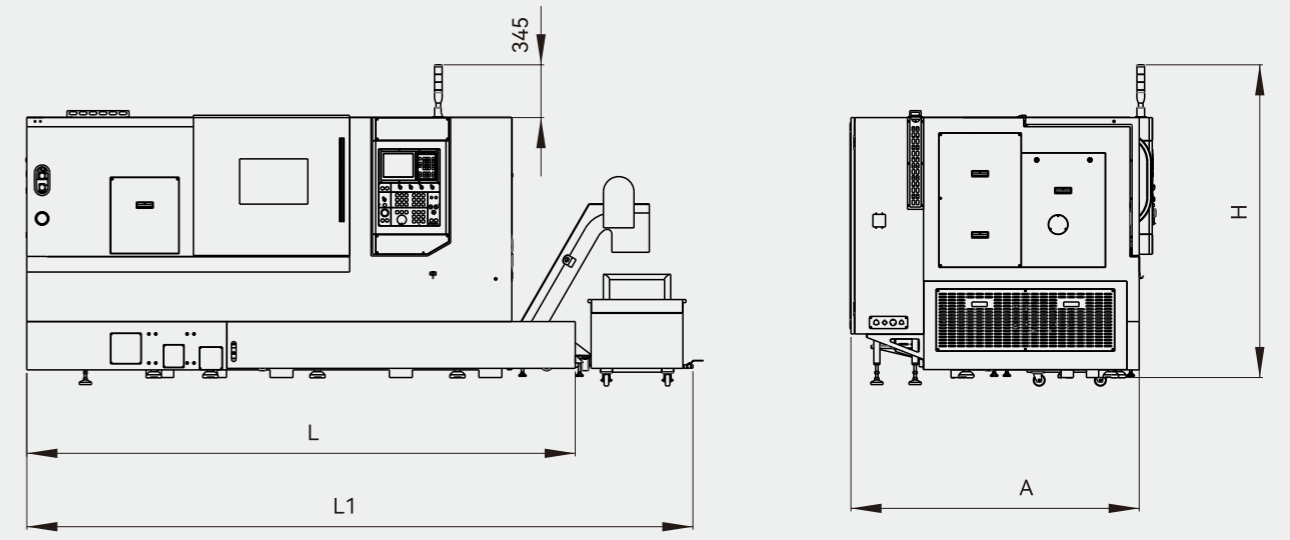

标准尺寸 Standard dimensions

设备型号 Equipment model	L	L1	H	A
L-45YP	3585	4500	2360	1880

高精度数控卧式车铣复合

HIGH-PRECISION CNC HORIZONTAL TURNING (MILLING) COMPOUND

工艺强大，一机多能、多品种、小批量，一次装夹可完成多样加工的个性化市场制造需求，满足复杂的零件加工需要，广泛应用于阀门、船舶和工程机械等领域，尤其受到汽车零部件制造企业的青睐。

Powerful technology enables the machine to be versatile, capable of handling multiple varieties and small batch production. With the ability to complete various machining processes in a single setup, it meets the demands of personalized market manufacturing. It is suitable for complex part machining and finds wide applications in industries such as valves, shipbuilding, and construction machinery. It is especially favored by automotive component manufacturers.



高精度数控卧式车铣复合

L-25M/L-35M/L-45M/L-45MP

- ★ 高刚性、低振动的30度斜床鞍结构设计延长了刀具使用寿命。
- ★ 高精度、高刚性主轴结构，主轴跳动0.003mm以内。
- ★ 高精度、高刚性、高稳定性伺服及动力刀塔。
- ★ X、Z轴丝杆采用进口C3级双向预紧力丝杆，高速静音，30m/min，响应速度快，定位精度高。
- ★ 按人体工程学原理设计，摆动式操作面板。
- ★ 自动化多种选项，实现更高生产效率。

- ★ The 30-degree slant bed saddle structure design with high rigidity and low vibration extends the tool life.
- ★ High-precision and high-rigidity spindle structure with spindle runout within 0.003mm.
- ★ High-precision, high-rigidity, and high-stability servo and power tool turret.
- ★ X and Z axes adopt imported C3-grade bidirectional pre-tensioned ball screws, featuring high speed, low noise, with a rapid response and high positioning accuracy.
- ★ Designed according to ergonomic principles, featuring a swing-type control panel.
- ★ Various automation options available to achieve higher production efficiency.

高精·高效·智能

HIGH PRECISION HIGH EFFICIENCY INTELLIGENT

30°一体式床身结构特性
Characteristics of the 30° integrated bed structure

完美的刚性与稳定性
Perfect rigidity and stability

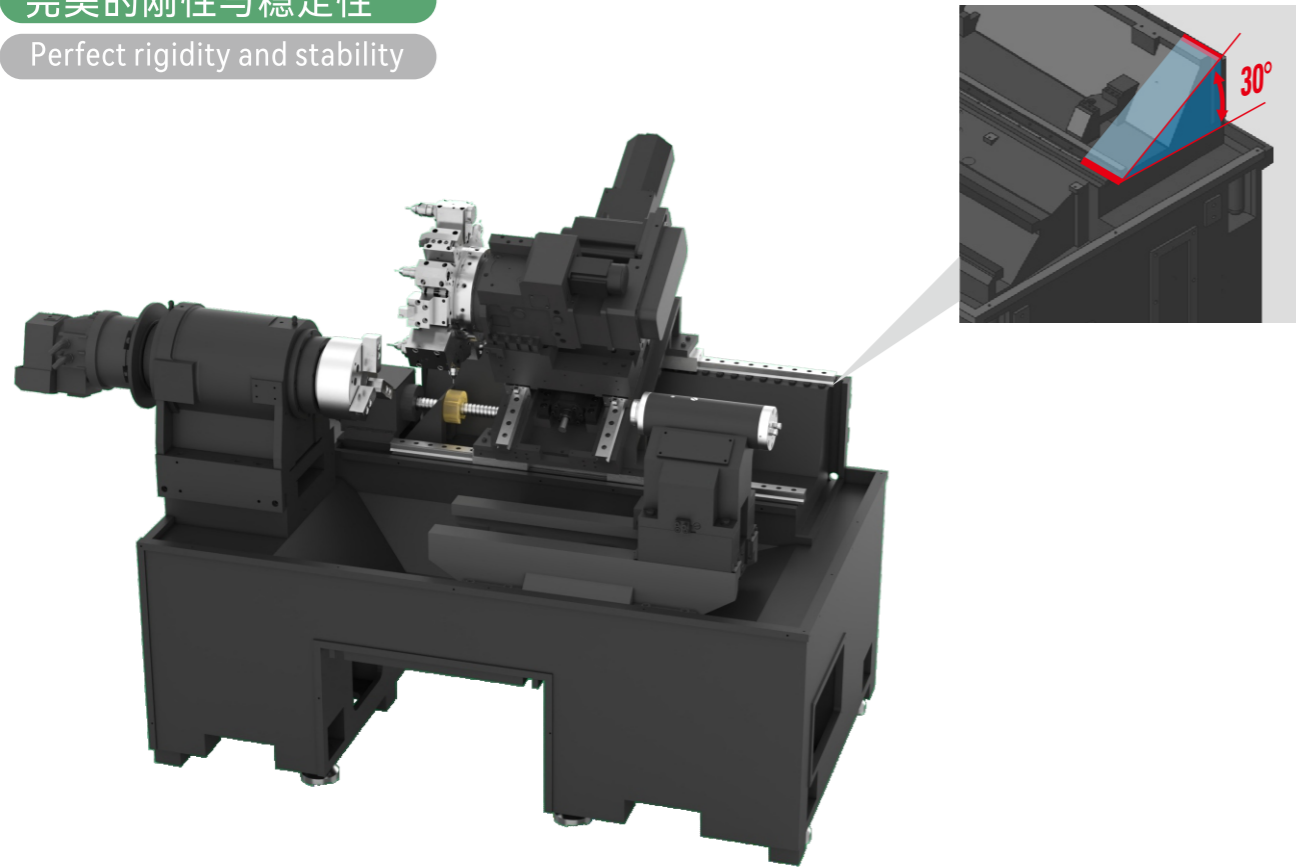

高刚性:
30°一体式高刚性斜床身设计, 经过有限元分析, 优化加强筋布局, 使机床具有优良的刚性、低振动, 同时实现最小占地面积。

高稳定性:
所有铸件均经过长时间的自然时效处理, 并在精加工前进行二次振动时效处理, 以消除铸件内部残余应力, 确保精度持久稳定。

高承载性
X/Z轴采用进口P级重载荷35mm滚柱导轨采用大跨距结构设计, 可满足高负荷作业。

High rigidity:
The 30° integrated high-rigidity slant bed design, optimized with finite element analysis and reinforced rib layout, provides excellent rigidity, low vibration, and minimal footprint for the machine tool.

High stability:
All castings undergo long-term natural aging treatment and secondary vibration aging treatment before precision machining to eliminate residual internal stress in the castings, ensuring long-lasting stability of accuracy.

High load-bearing capacity:
The X/Z axes are equipped with imported P-grade heavy-duty 35mm roller guide ways with a large span structure design, capable of handling high-load operations.

机器外观尺寸图 Machine exterior dimensions diagram

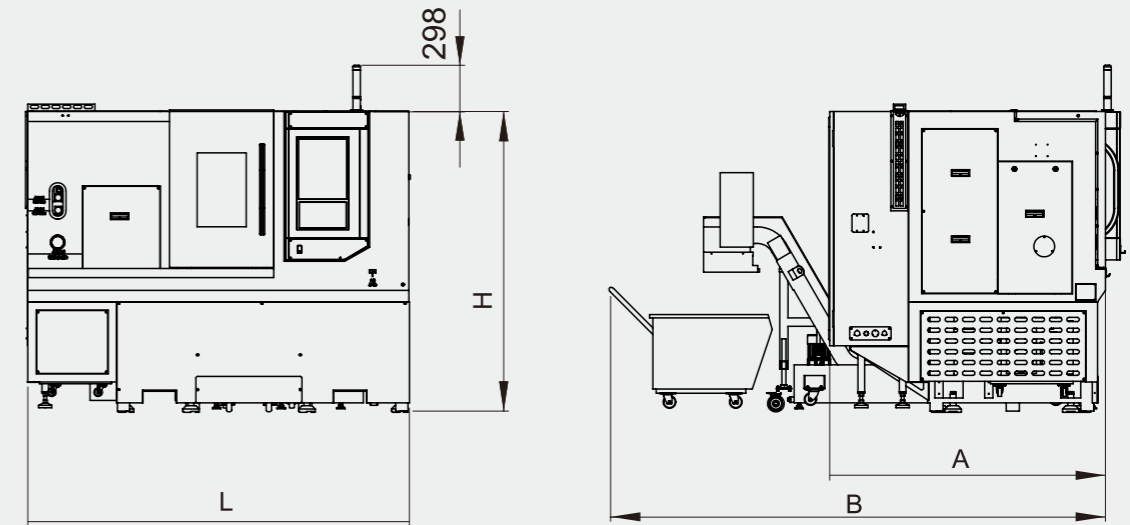

标准尺寸 Standard dimensions

设备型号 Equipment model	L	H	A	B
L-35M/L-45M	2300	1800	1880	3000

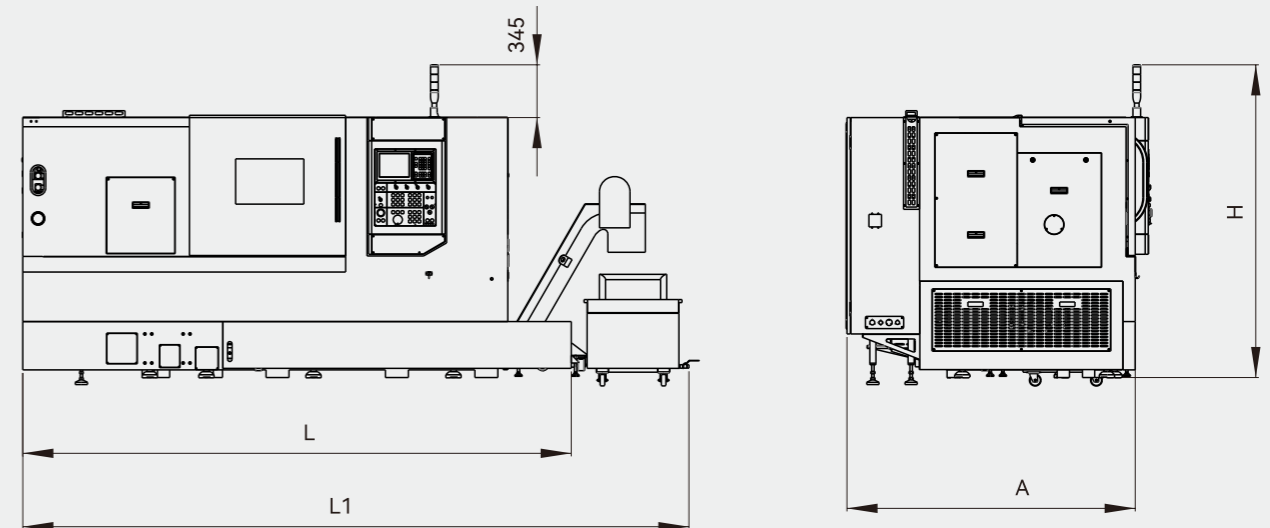

标准尺寸 Standard dimensions

设备型号 Equipment model	L	L1	H	A
L-45MP	3585	4500	2100	1880

高精度数控卧式车铣复合

HIGH-PRECISION CNC HORIZONTAL TURNING (MILLING) COMPOUND

工艺强大，一机多能、多品种、小批量，一次装夹可完成多样加工的个性化市场制造需求，满足复杂的零件加工需要，广泛应用于阀门、船舶和工程机械等领域，尤其受到汽车零部件制造企业的青睐。

Powerful technology enables the machine to be versatile, capable of handling multiple varieties and small batch production. With the ability to complete various machining processes in a single setup, it meets the demands of personalized market manufacturing. It is suitable for complex part machining and finds wide applications in industries such as valves, shipbuilding, and construction machinery. It is especially favored by automotive component manufacturers.

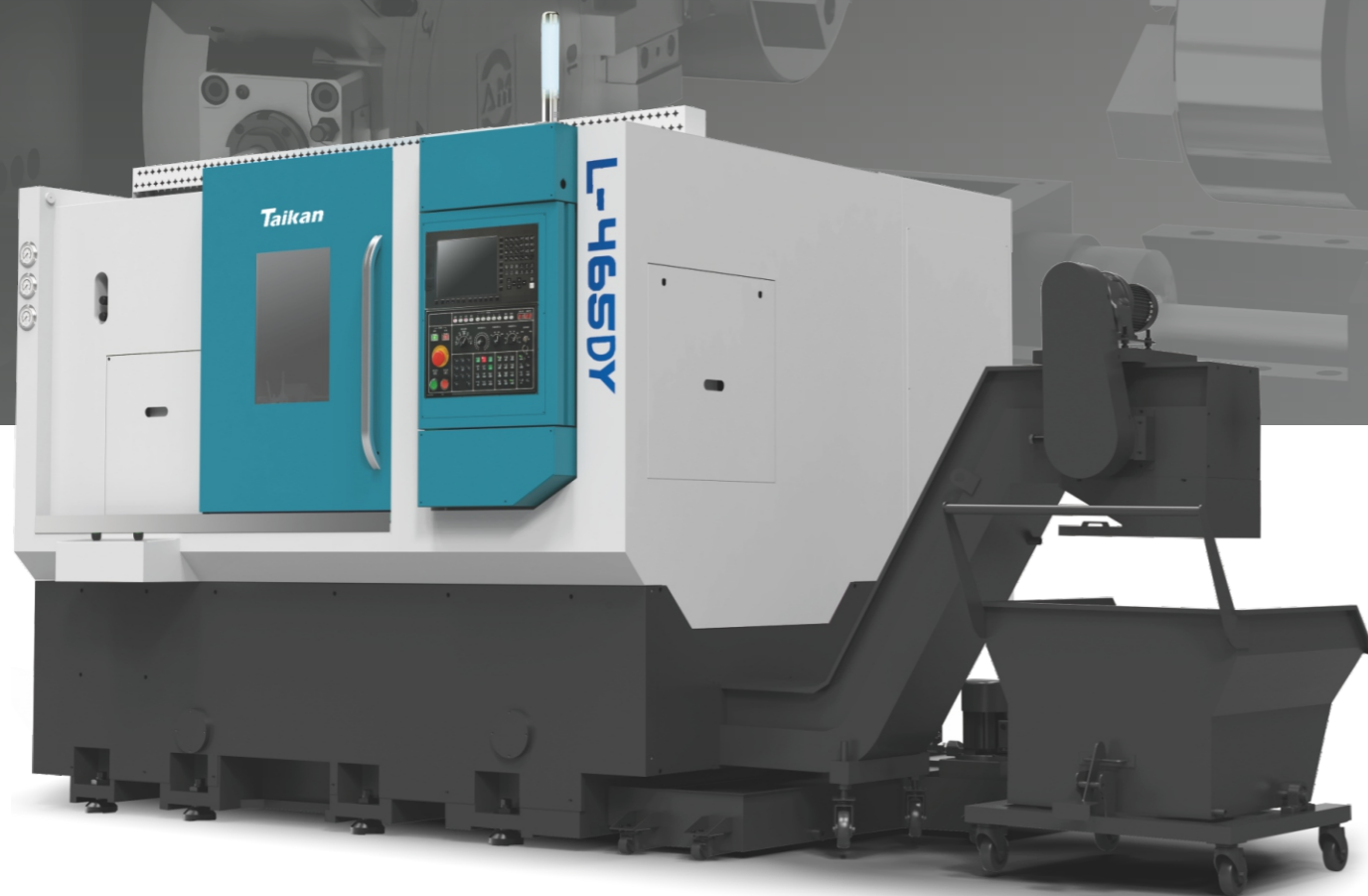

高精度数控卧式车铣复合

L-46SDY/L-52SDY

- ★ 高刚性、低振动的30度斜床鞍结构设计延长了刀具使用寿命。
- ★ 高精度、高刚性主轴结构，主轴跳动0.003mm以内。
- ★ 高精度、高刚性、高稳定性Y轴动力刀塔。
- ★ X、Z轴丝杆采用进口C3级双向预紧力丝杆，高速静音，30m/min，响应速度快，定位精度高。
- ★ 按人体工程学原理设计，摆动式操作面板。
- ★ 自动化多种选项，实现更高生产效率。

- ★ High precision, high rigidity, and low vibration 30-degree slant bed saddle design extends tool life.
- ★ High precision, high rigidity spindle structure with spindle runout within 0.003mm.
- ★ High precision, high rigidity, and high stability Y-axis power turret.
- ★ X and Z axes adopt imported C3-grade bi-directional preloaded ball screws, featuring high speed, low noise, fast response, and high positioning accuracy.
- ★ Designed according to ergonomic principles, with a swing-type operation panel.
- ★ Multiple automation options available to achieve higher production efficiency.
- ★ Incorporating advanced technologies, such as high precision, high efficiency, and intelligent features.

高精·高效·智能

HIGH PRECISION HIGH EFFICIENCY INTELLIGENT

30°一体式床身结构特性
Characteristics of the 30° integrated bed structure

完美的刚性与稳定性

Perfect rigidity and stability

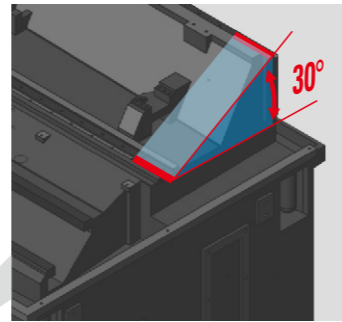
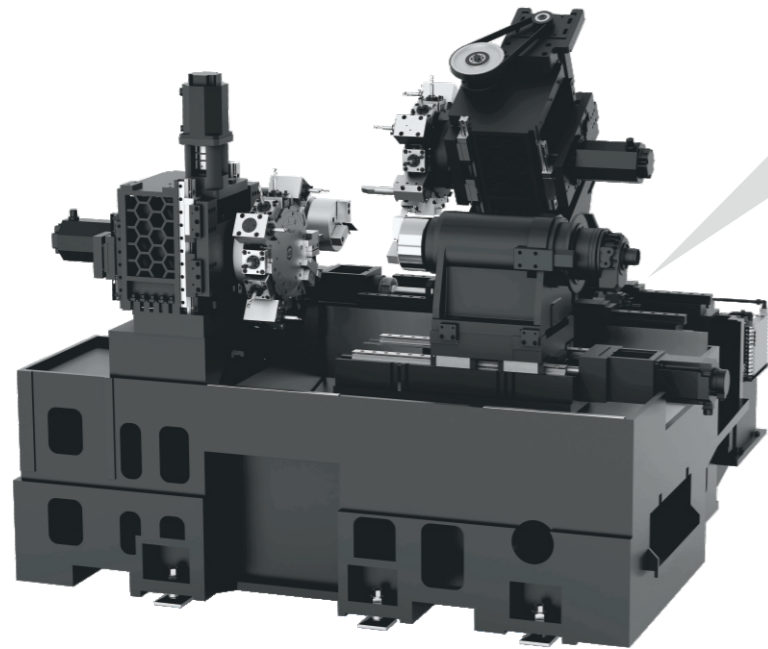

双主轴双刀塔

双主轴双刀塔升降数控车床型数控车床系双通道12轴联动，全闭环控制的双主轴数控车床。主机采用整体一斜一平床身结构，双主轴、双拖板、滑板结构布置，采用日本THK直线滚动导轨，日本THK滚珠丝杠驱动。

Dual Spindle Dual Turret CNC Lathe

The Dual Spindle Dual Turret CNC Lathe is a CNC lathe with two spindles and two turrets that operate in a synchronized manner with 12 axes. It features a fully closed-loop control system. The machine is equipped with a monolithic slant bed structure, dual spindles, dual tail stocks, and a saddle arrangement. It utilizes THK linear roller guides from Japan and THK ball screw drives.



永磁同步电主轴

动态特性好，精度高，刚性强。防护采用全封闭防护，单开左移门，配自动出料装置，独立集屑水箱，配好排屑机，排屑性能好。控制系统采用台湾新代12轴控制系统及交流伺服电机、驱动。双主轴最大的优点是实现自动化上下料，工件两面一次性对接加工完成工件，节省人工提高效率。

Permanent Magnet Synchronous Electric Spindle

The permanent magnet synchronous electric spindle is characterized by excellent dynamic performance, high precision, and strong rigidity. It is equipped with a fully enclosed protection system, a single-opening left sliding door, an automatic chip removal device, an independent chip collection water tank, and a well-configured chip conveyor with excellent chip removal performance. The control system utilizes the Taiwan New Generation 12-axis control system and AC servo motors and drives. The greatest advantage of the dual spindles is the automation of loading and unloading, allowing for the simultaneous machining of both sides of the workpiece, saving labor and improving efficiency.

加工能力图 Processing Capacity Chart

L-35M

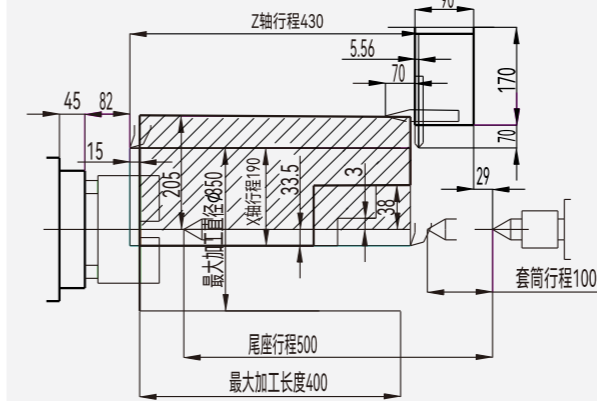

L-35Y

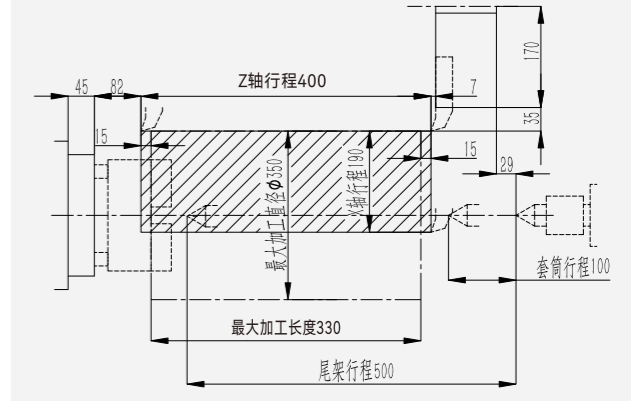

L-45M

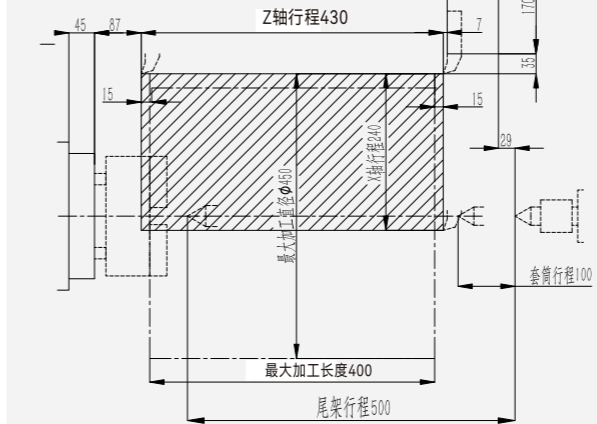

L-45YP

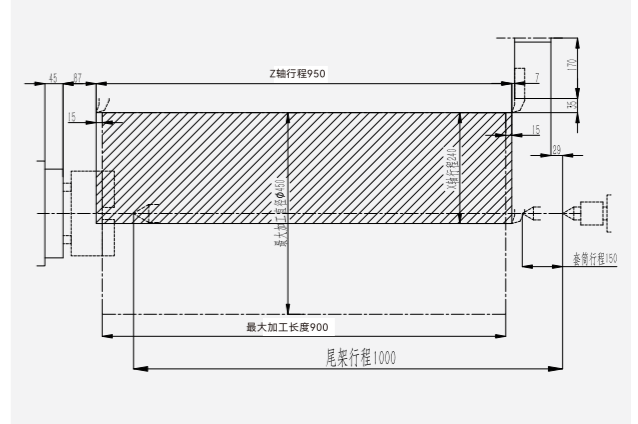

L-45MP

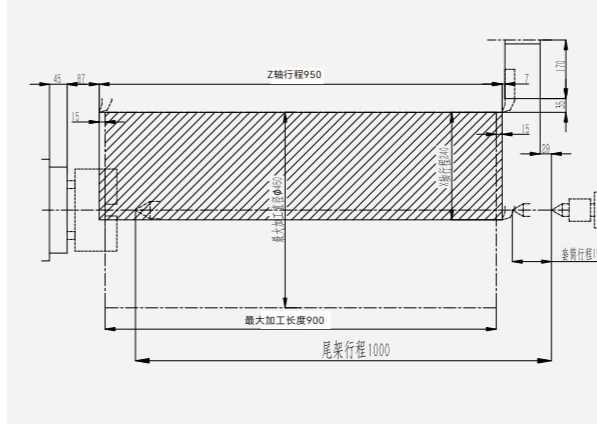

刀具干涉图 Tool interference diagram

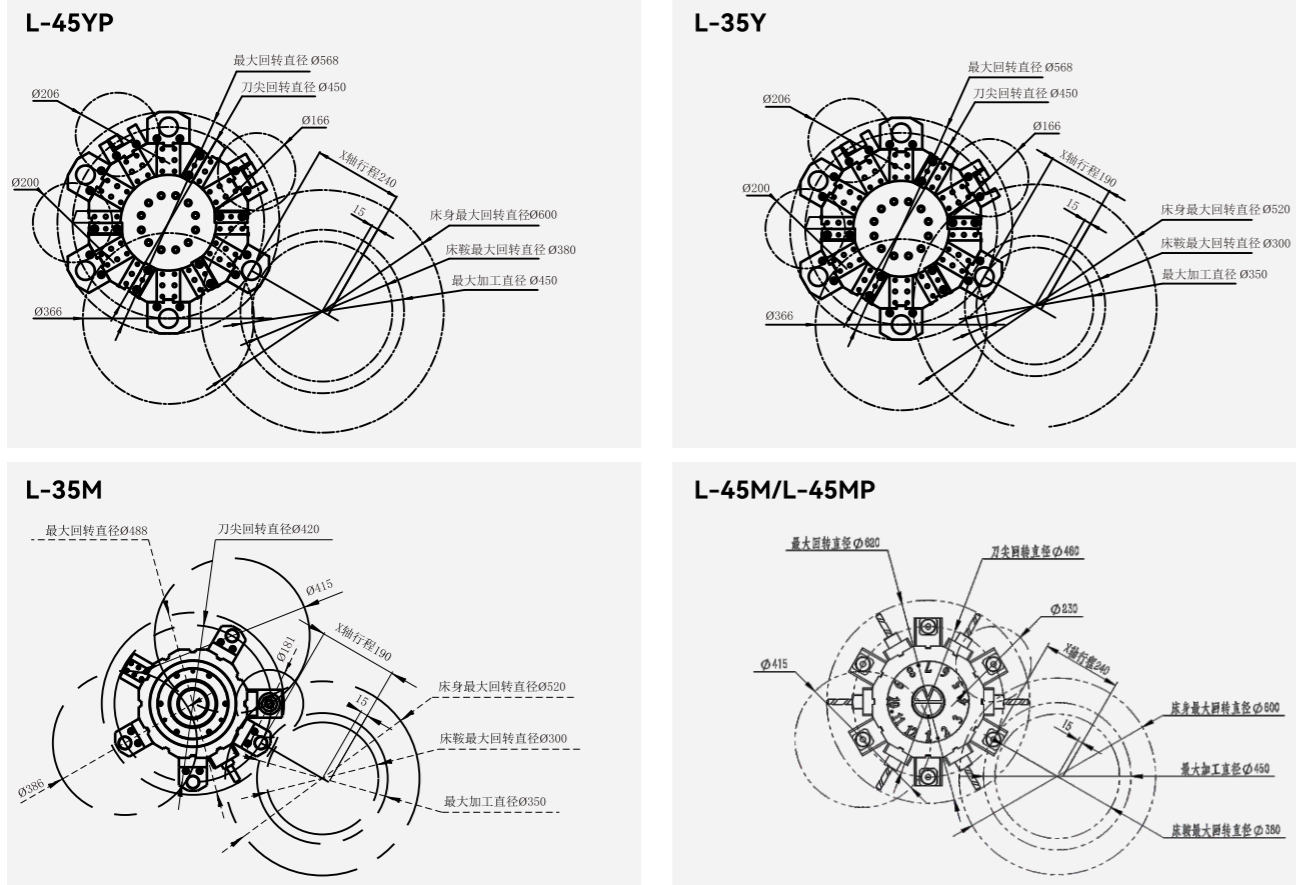

参数表 Parameter Table

类别 Category	名称 Name	L-25M	L-25Y	L-35M	L-35Y	L-45M	L-45MP
加工范围 Machining range	床身上最大回转直径(mm) Maximum swing diameter on the bed (mm)	Ø520	Ø520	Ø520	Ø520	Ø600	Ø600
	最大加工直径(轴/盘)(mm) Maximum machining diameter (shaft/disc) (mm)	Ø200/Ø250	Ø300/Ø350	Ø300/Ø350	Ø300/Ø350	Ø380/Ø450	Ø380/Ø450
	最大加工长度(mm) Maximum machining length (mm)	400	330	400	330	400	900
	最大棒料直径(mm) Maximum bar diameter (mm)	Ø45	Ø52	Ø52	Ø52	Ø52	Ø75
行程 Travel	X轴行程(mm) X-axis travel (mm)	190	190	190	200	240	240
	Y轴行程(mm) Y-axis travel (mm)	/	100(±50)	/	100(±50)	/	/
	Z轴行程(mm) Z-axis travel (mm)	430	400	430	400	430	950
主轴 Spindle	输出功率(kw) Output power (kW)	7.5/11.25	7.5/11	7.5/11	11/15	14.5/17.8	15/18.5
	主轴头形式 Spindle head form	A2-5	A2-5	A2-6	A2-6	A2-6	A2-8
	主轴最高转速(rpm) Maximum spindle speed (rpm)	5300	6000	4000	4000	4000	2500
	主轴通孔直径(mm) Spindle through-hole diameter (mm)	Ø57	Ø67	Ø63	Ø63	Ø67	Ø103
刀架 Tool turret	刀塔形式及刀具容量 Turret type and tool capacity		动力BMT45/12	动力BMT45/12	动力BMT45 (含Y轴)/12	动力BMT55/12	动力BMT55/12
	外圆刀具尺寸(mm) External tool dimensions (mm)	/	/	25×25	25×25	25×25	25×25
	最大镗刀直径(mm) Maximum boring tool diameter	Ø32	Ø32	Ø32	Ø32	Ø40	Ø32
快移速度 Rapid traverse speed	X/Z轴(mm/min) X/Zaxis(mm/min)	30000	30000	30000	30000	30000	30000
进给速度 feed rate	进给速度(mm/min) Feed speed (mm/min)	1-8000	1-8000	1-8000	1-8000	1-8000	1-8000
尾架 Tailstock	尾架形式及锥形孔形式 Tailstock type and taper hole type	莫氏4#	莫氏4#	液压套筒 莫氏4#	液压套筒 莫氏4#	液压套筒 莫氏4#	液压套筒 莫氏5#
	尾架套筒行程 (mm) Tailstock sleeve travel (mm)	100	80	70/100	70/100	70/100	100/150
	最大移动量 (mm) Maximum travel distance (mm)	/	/	X/190 Z/430	X/200 Z/400	X/240 Z/430	/
控制系统 Control system	NC形式 NC form	FANUC 0i TF(5)	FANUC 0i TF(5)	FANUC 0i TF(5)	FANUC 0i TF(5)	FANUC 0i TF(5)	FANUC 0i TF(5)
排屑形式 Chip removal form		/	/	自动后排	自动后排	自动后排	自动后排

机器外观尺寸图 Machine exterior dimensions diagram

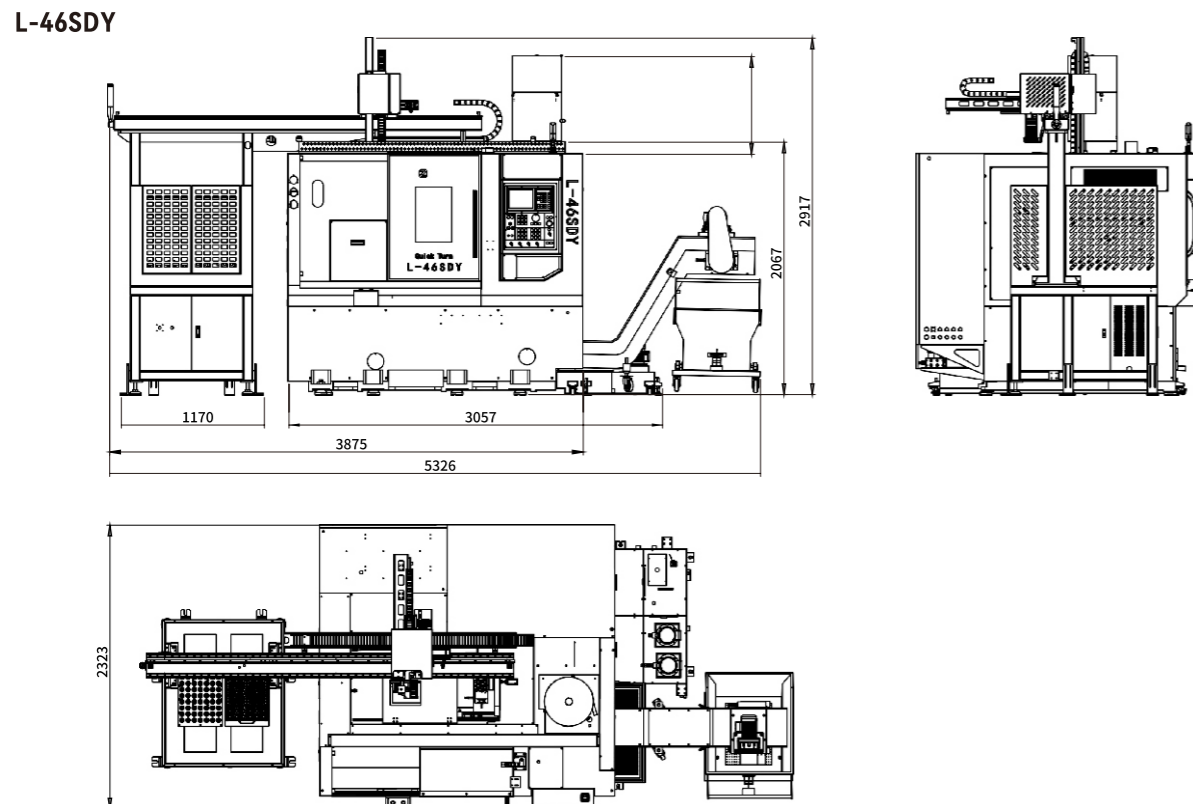

本画册内所有图片仅供参考，以实际交付为准；本公司产品不断改进，上述资料若有变更，恕不另行通知。
 All images in this catalog are for reference only. Actual delivery may vary. Our company continuously improves its products, and in the event of any changes to the above information, no separate notice will be given.

加工案例 Processing Cases

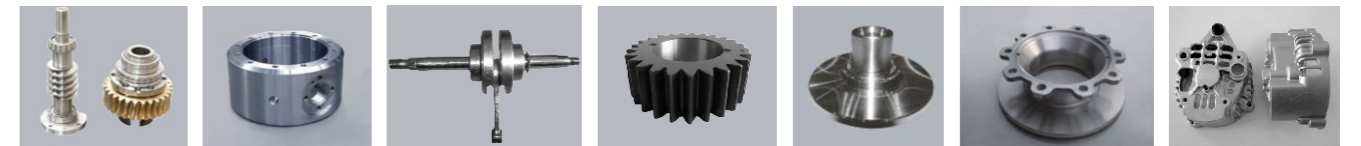

配置表 Configuration Table

项 目 Project	L-25M	L-25Y	L-35M	L-35Y	L-45M	L-45Y	L-45MP	L-45YP
主轴头A2-5 Spindle head A2-5	√	√	★	★	★	★	★	√
主轴头A2-6 Spindle head A2-6	★	★	√	√	√	√	√	★
主轴头A2-8 Spindle head A2-8	×	×	★	★	★	★	★	★
三色灯 tricolor light	√	√	√	√	√	√	√	√
液压系统 hydraulic system	√	√	√	√	√	√	√	√
照明灯 floodlight	√	√	√	√	√	√	√	√
冷却系统 Cooling system	√	√	√	√	√	√	√	√
安全门锁 Safety door lock	★	★	★	★	★	★	★	★
对刀仪 Tool Setter	★	★	★	★	★	★	★	★
接料装置 Material Feeding Device	★	★	★	★	★	★	★	★
自动润滑系统 Automatic Lubrication System	√	√	√	√	√	√	√	√
6寸中空卡盘油缸 6-inch hollow chuck oil cylinder	√	√	★	★	★	★	★	√
8寸中空卡盘油缸 8-inch hollow chuck oil cylinder	★	★	√	√	√	√	√	★
油雾收集器 Oil mist collector	★	★	★	★	★	★	★	★
油水分离器 water separator	★	★	★	★	★	★	★	★
动力刀塔 Power turret	√	√	√	√	√	√	√	√
送料机 feeder	★	★	★	★	★	★	★	★

√ 标准配置 ★ 可选配置 × 不可选
 √ Standard configuration ★ Optional configuration × Not available

参数表 Parameter Table

类 别Category	名 称 Name	单 位 unit	L-46SDY	L-52SDY
作业能力 Work capacity	最大回转直径 Maximum swing diameter	mm	Ø570	Ø570
	滑鞍上最大回转直径 Maximum turning diameter on the saddle	mm	Ø320	Ø320
	最大车削直径 Maximum turning diameter	mm	Ø130	Ø130
	最大车削长度 Maximum turning length	mm	130	130
行程 Axis	X1、X2轴行程 X1 and X2 axis travel	mm	200/300	200/300
	Y1、Y2轴行程 Y1 and Y2 axis travel	mm	±50	±50
	Z1、Z2轴行程 Z1 and Z2 axis travel	mm	320/300	320/300
主轴 Spindle	卡盘尺寸 chuck size	inch	6"	8"
	最高转速 Maximum speed	rpm	6000	4500
	主轴端型式 Spindle end type	/	A2-5	A2-6
副主轴 Sub-spindle	卡盘尺寸 chuck size	inch	6"	6"
	最高转速 Maximum speed	rpm	6000	6000
	主轴端型式 Spindle end type	/	A2-5	A2-6
铣削主轴 Milling spindle	最高转速 Maximum speed	rpm	4000	4500
	钻孔能力 Drill capacity	mm	Ø16X1.5	Ø16x1.5
	铣削主轴电机 Milling spindle motor	KW	2.7	2.3
	刀塔 tool turret	/	BMT45	BMT45
进给速度 Feed Speed	X-轴快速进速度 X-axis fast forward speed	mm/min	18000	18000
	Z-轴快速进速度 Z-axis fast forward speed	mm/min	18000	18000
	Y-轴快速进速度 Y-axis fast forward speed	mm/min	10000	10000
电机 Electrical Motor	主轴电机 spindle motor	KW	11	11
	冷却泵电机 Cooling pump motor	KW	0.75	0.75
电/气源 Electricity/Gas	电源容量 (连续定额) Power capacity (continuous rating)	KVA	64/44.75	64/44.75
	气源 Air source	L/min	0.5Mpa/100	0.5Mpa/100
冷却 Burial	水箱容量 Water tank capacity	L	130	130
尺寸/重量 Size/Weight	主轴中心到地面距离 Distance from spindle center to ground	mm	1070	1070
	机床高度 Machine height	mm	2060	2060
	占地面积 (L×W) Battlefield area (L × W)	mmxmm	2410×2210	2410×2210
	机床重量(约) Machine weight (approximately)	Kg	5000	5000

配置表 Configuration Table

项目 Project	L-46SDY	L-52SDY	品牌 Brand
控制系统 Control system	新代/发那科	新代/发那科	新代/发那科
伺服电机 servo motor	X/X1/Z/Z1	X/X1/Z/Z1	
刀塔电机 Turret motor	/		
刀塔旋转电机 Turret rotation motor	/		
刀塔单元 Turret unit	正交Y轴刀塔-BMT45/BMT45	正交Y轴刀塔-BMT45+BMT55	/
主驱动 main drive	驱动功率, 11千瓦	驱动功率, 11千瓦	新代/发那科
电主轴 Electric spindle	11千瓦	11千瓦	创世纪
滚珠丝杠 Ball screw	X/X1/Z/Z1 $\Phi 32 \times 10$	X/X1/Z/Z1 $\Phi 32 \times 10$	PMI/hiwin
直线导轨 Linear guide rail	X/X1/Z/Z1 35导轨	X/X1/Z/Z1 35导轨	PMI/hiwin
丝杠轴承 Screw bearing	25TAC62C SU PN7C	25TAC62C SU PN7C	NSK
主轴卡盘 Spindle chuck	3H-206-A5	3H-208-A6	佳贺
副主轴卡盘 Auxiliary spindle chuck	3H-206-A5	3H-206-A5	
主轴油缸 Spindle oil cylinder	TK-B646	TH-852	
副轴油缸 Countershaft oil cylinder	TK-B646	TK-B646	
自动润滑装置 Automatic lubrication device	TZ2212+容积式分配器	TZ2212+容积式分配器	宝腾
冷却水泵 Cooling water pump	750W; 80L/min	750W; 80L/min	洛锐
油冷机 Oil cooler	LCO-15FPT	LCO-15FPT	菱基
排屑器 Chip conveyor	链板式	链板式	智杰

双主轴双刀塔加工干涉图 Interference diagram for dual spindle dual turret machining

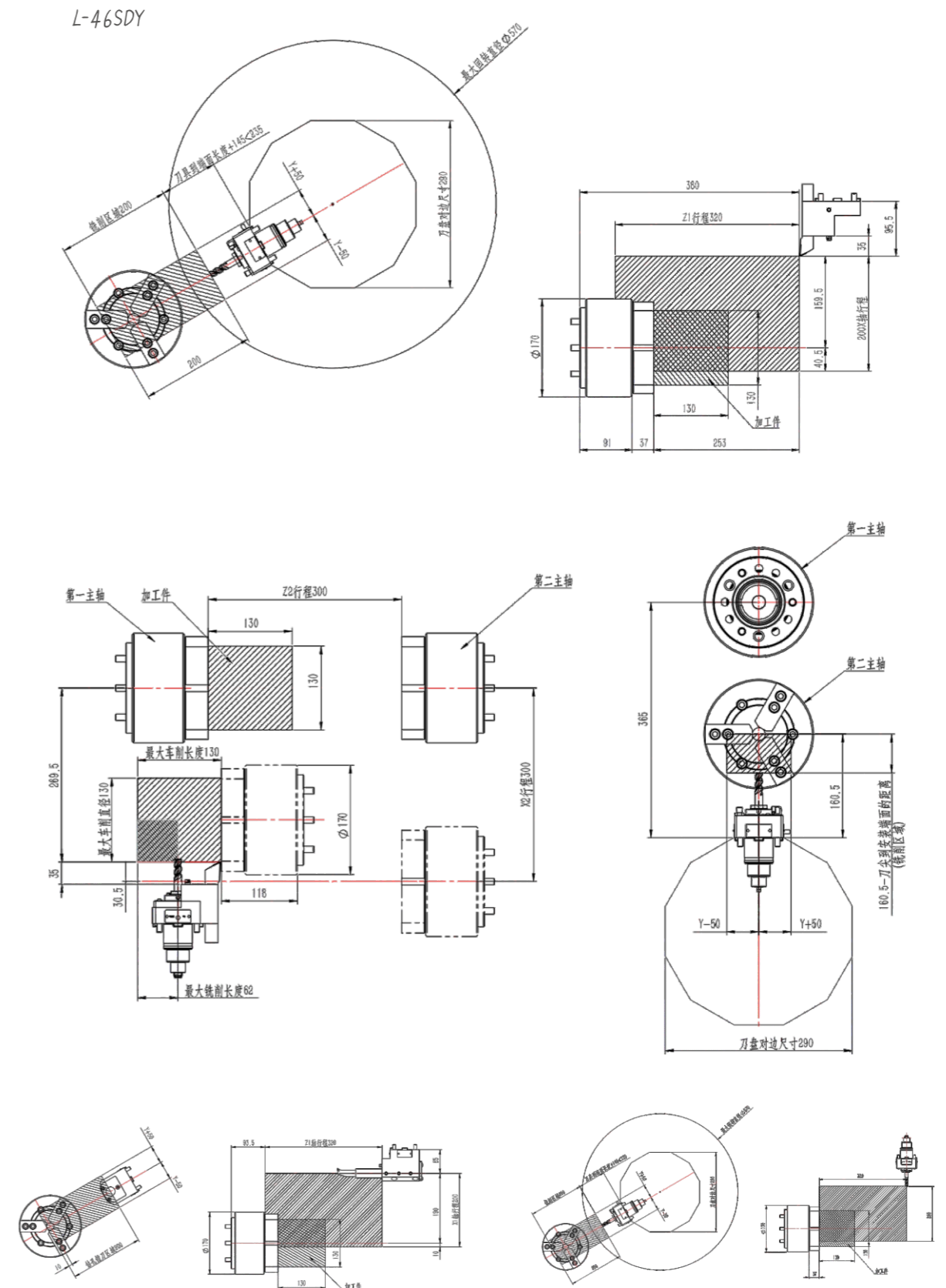

精密排刀式数控车(铣)床

Precision turret-type CNC lathe (milling) machine

这款精密排刀系列数控车床，在市场调研分析的基础上进行了优化整合设计，与刀塔车系列进行高低搭配，可满足客户多样化加工需求。

This precision turret series CNC lathe has been optimized and designed through market research and analysis. It is compatible with the turret lathe series, allowing for a flexible combination of high and low models to meet diverse customer machining requirements.



高精度数控卧式车铣复合

L-P30Y/L-P46Y

- ★机电一体化设计，占用空间小，造型美观结构合理。
- ★主轴采用高精度主轴单元，噪音小，转速高，使用寿命长。主轴跳动0.002mm以内。
- ★导轨采用高精度直线导轨，定位精度高，动态性能好，快移速度可达30m/min。重复定位精度可达到0.002mm。
- ★T型排刀板减少换刀时间，多样的刀具排列组合提高生产效率。
- ★全防式内防护，有效区隔加工区域，防水，防油，防尘效果好。
- ★自动化多种选项，实现更高生产效率。

- ★Integrated design of mechanics and electronics, compact size, and aesthetically pleasing structure.
- ★The main spindle adopts a high-precision spindle unit, with low noise, high speed, and long service life. The spindle runout is within 0.002mm.
- ★High-precision linear guides are used, providing good positioning accuracy, excellent dynamic performance, and a rapid traverse speed of up to 30m/min. The repeat positioning accuracy can reach 0.002mm.
- ★The T-slot tool changer reduces tool change time, and the diverse arrangement of tools improves production efficiency.
- ★Full enclosure design effectively separates the machining area, providing good water, oil, and dust resistance.
- ★Various automation options are available to achieve higher production efficiency.

高精·高效·智能

HIGH PRECISION HIGH EFFICIENCY INTELLIGENT



刀具干涉图 Tool interference diagram

L-P30Y

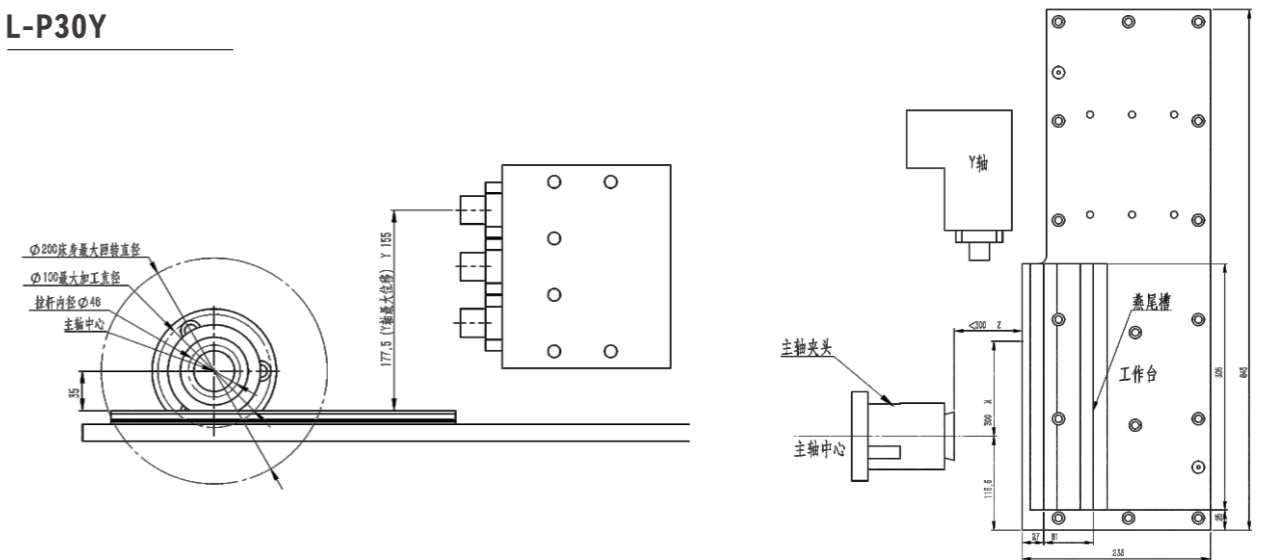

机器外观尺寸图 Machine exterior dimensions diagram

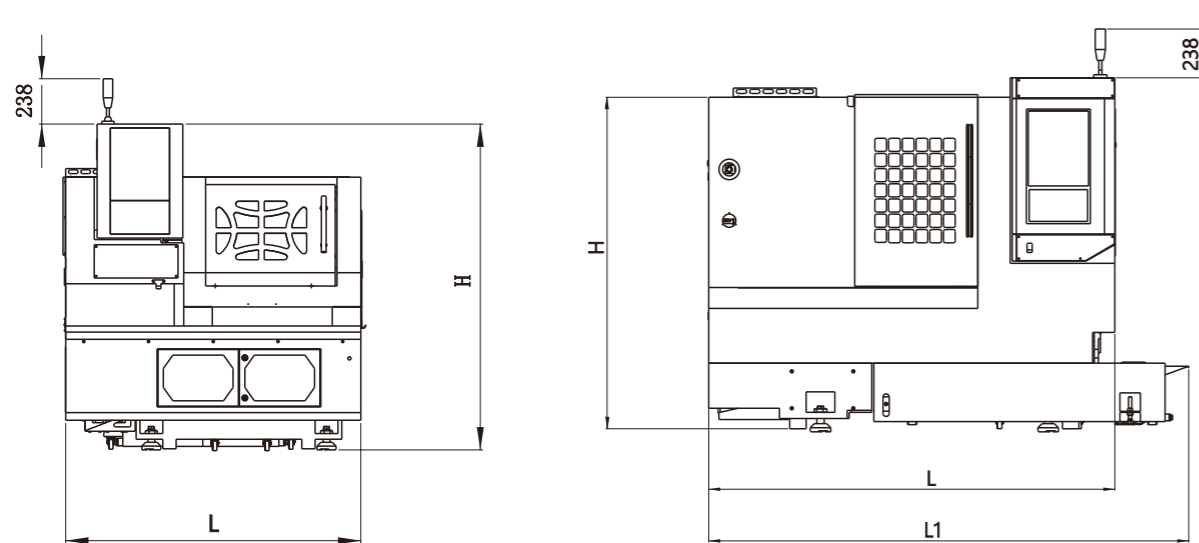

标准尺寸 Standard dimensions

设备型号 Equipment model	L	L1	L2	H	A	B
L-P30Y	1550	1500	1950	1750	1350	1500
L-P46Y	2040	2400	/	1560	2000	1800

L-P46Y

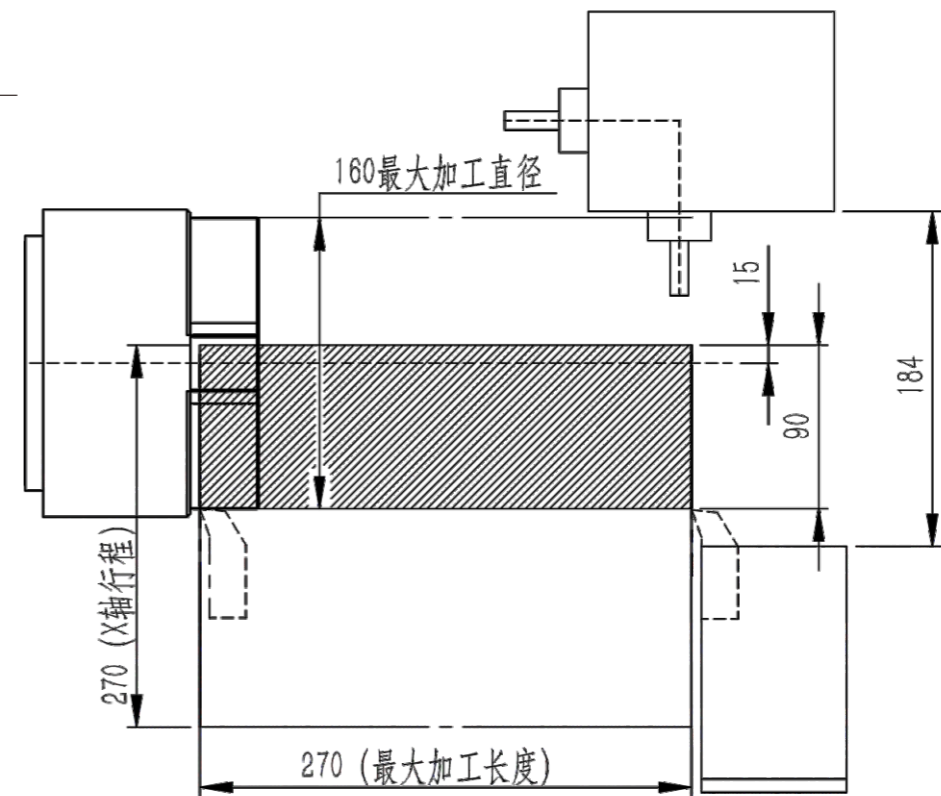

参数表 Parameter Table

类别 Category	名称 Name	L-P30Y	L-P46Y
加工范围 Machining range	床身上最大回转直径(mm) Maximum swing diameter on the bed (mm)	Ø480	Ø500
	最大加工直径(轴/盘)(mm) Maximum machining diameter (shaft/disc) (mm)	Ø160/Ø300	Ø300
	最大加工长度(mm) Maximum machining length (mm)	270	350
	最大棒料直径(mm) Maximum bar diameter (mm)	Ø45	Ø30
行程 Travel	X轴行程(mm) X-axis travel (mm)	270	450
	Y轴行程(mm) Y-axis travel (mm)	230	260
	Z轴行程(mm) Z-axis travel (mm)	270	400
主轴 Spindle	输出功率(kw) Output power (kW)	7.5/11	7.5/11
	主轴头形式 Spindle head form	A2-5	A2-5
	主轴通孔直径 (mm) Spindle through-hole diameter (mm)	Ø57	Ø56
	主轴最高转速(rpm) Maximum spindle speed (rpm)	6000	6000
刀架 Tool turret	刀塔形式 Knife tower form	伺服刀塔	伺服刀塔
	刀具容量 Tool capacity	8	8
	车刀刀体尺寸(mm) Turning tool body size (mm)	Ø16	/
	最大镗刀直径(mm) Maximum boring tool diameter	Ø32	Ø32
快移速度 Rapid traverse speed	X/Z轴(m/min) X/Zaxis(mm/min)	30/30	/
进给速度 feed rate	进给速度(mm/min) Feed speed (mm/min)	1-8000	1-8000
控制系统 Control system	NC形式 NC form	新代22TB系统	新代22TB系统
排屑形式 Chip removal form		手动右排	手动后屑

本画册内所有图片仅供参考，以实际交付为准；本公司产品不断改进，上述资料若有变更，恕不另行通知。
All images in this catalog are for reference only. Actual delivery may vary. Our company continuously improves its products, and in the event of any changes to the above information, no separate notice will be given.

加工案例 Processing Cases



配置表 Configuration Table

项目 Project	L-P30Y	L-P46Y
主轴头A2-4 Spindle head A2-4	√	×
主轴头A2-5 Spindle head A2-5	×	√
4寸中空筒夹油缸 4-inch hollow chuck oil cylinder	×	×
5寸中空筒夹油缸 5-inch hollow chuck oil cylinder	√	×
6寸中空筒夹油缸 6-inch hollow chuck oil cylinder	×	√
8工位伺服刀塔 8-inch hollow chuck oil cylinder	×	√
侧排屑 (自动) Side chip removal (automatic)	×	★
侧排屑 (手动) Side chip removal (manual)	√	√
后排屑 (自动) Rear Chip Conveyor (Automatic)	★	★
棒料机 Bar Feeder	★	★
自动接料装置 Automatic material receiving device	★	★
油雾收集器 Oil mist collector	★	★
高压出水 High pressure water outlet	★	★
自动门 Automatic Door	★	★
副主轴 Auxiliary spindle	×	★
光栅尺 Grating ruler	★	★
安全门光栅 Safety door light curtain	★	★

√ 标准配置 ★ 可选配置 × 不可选
√ Standard configuration ★ Optional configuration × Not available

卡盘油缸
Chuck Hydraulic Cylinder



自动车床送料机
Automatic lathe feeding machine



车床送料机
Lathe feeder



机器人
Robot arm

